

Specifications for Communication Unit

PROFIBUS-DP

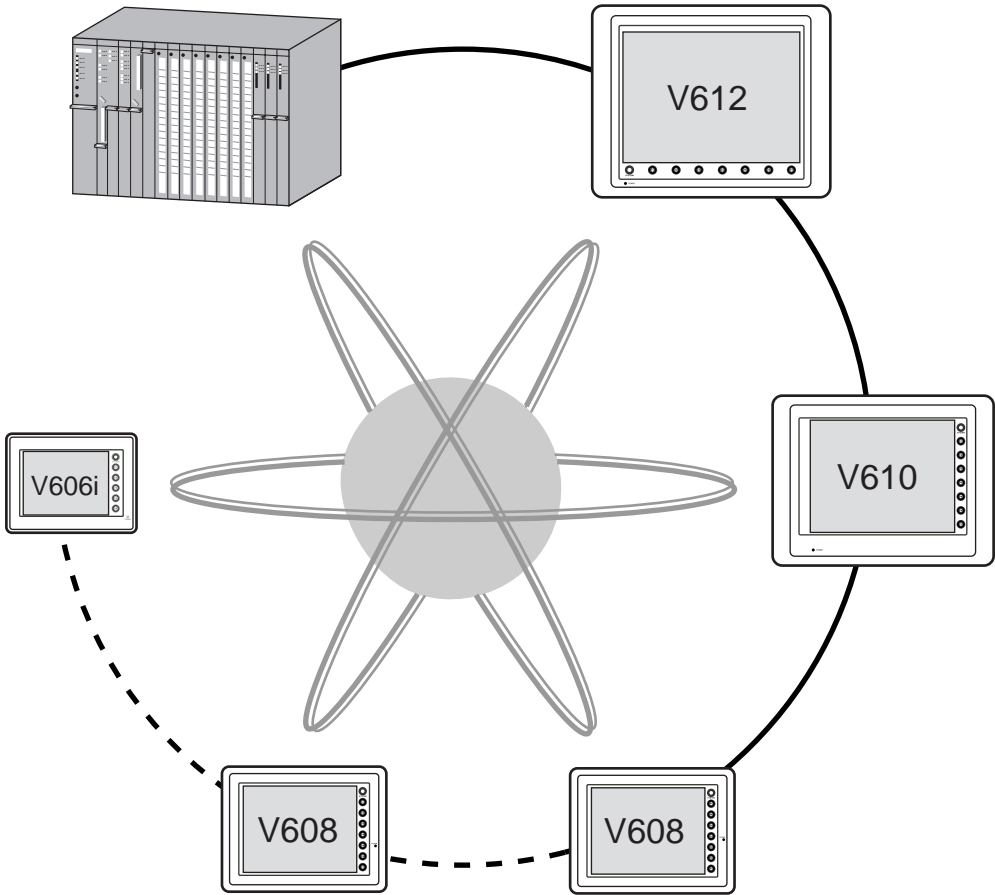

Contents

Chapter 1	Outline	1-1
Chapter 2	Specifications	2-1
	PROFIBUS Communication Specifications	2-1
Chapter 3	Settings at the V6 Side & Wiring	3-1
	Installation to the V6 and Settings	3-1
	Communication interface unit	3-1
	Dimensions of PROFIBUS I/F unit	3-2
	How to install a PROFIBUS I/F unit	3-3
	Setting at PROFIBUS I/F Unit Side	3-4
	Outline of PROFIBUS I/F unit	3-4
	Wiring	3-5
	Cable	3-5
	Recommended bus connector	3-5
	Notes on using V606i	3-6
Chapter 4	Connection to PLC	4-1
	Interpreting Communication	4-1
	Outline	4-1
	Available memories	4-2
	Setting in SIMATIC Manager	4-3
	Our software package	4-3
	Registration of V6 series	4-4
	Setting of Hardware Configuration	4-5
	Setting of Function	4-8
Chapter 5	Screen Data Editing	5-1
	Select PLC Type	5-1
	Communication Parameter	5-2
	No. of Words Setting for I/O	5-2

Chapter 6 Error..... 6-1

Communication Error (Time-Out) 6-1

If [Time-Out] happens instantly; 6-2

If [Time-Out] happens after a screen is displayed for a moment; 6-2

1

Outline

- © PROFIBUS is a vendor-independent, open field bus standard for a wide range of applications in manufacturing and process automation.

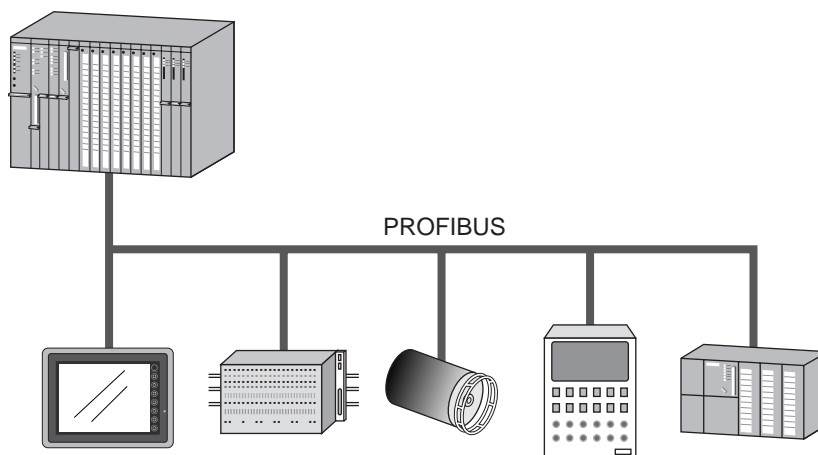

PROFIBUS offers functionally graduated communication protocols (Communication Profiles): DP and FMS. V6 series can communicate with PROFIBUS-DP.

◎ V6 series can communicate with PROFIBUS-DP with the communication interface unit, CU-04, attached onto V6 series.

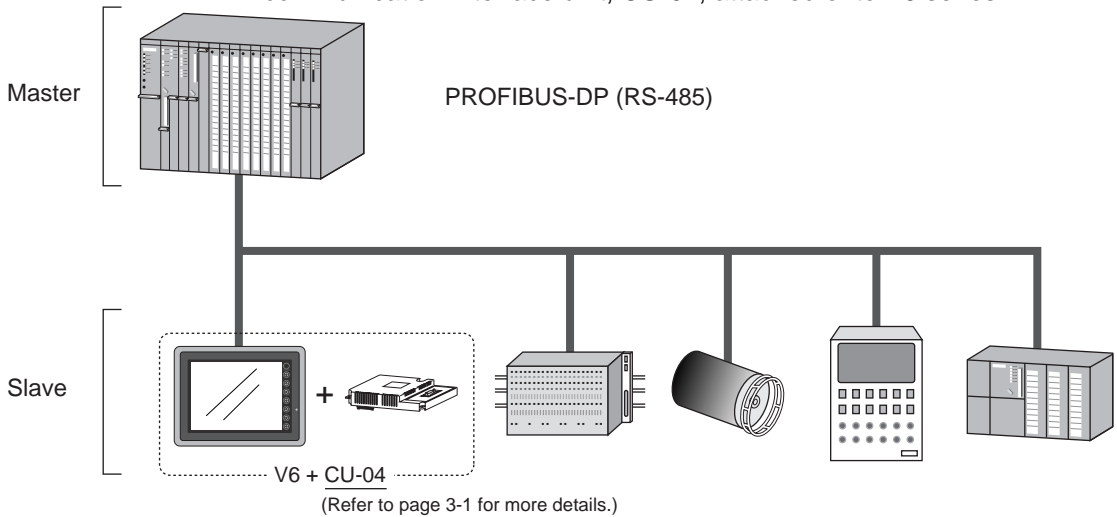

V6 can work as a slave on PROFIBUS-DP.

A maximum of 12M bps of the baud rate is supported. (V6 adjusts the baud rate to the bus's baud rate automatically.) The signal level is RS-485.

* **V6 can communicate with a master PLC only.**

◎ PROFIBUS-DP can only support the input/output communication with the cyclic data exchange.

In the input/output communication, the device memories in a CPU, such as DB, MW etc. cannot be accessed directly.

Therefore, we supply the original Function for SIEMENS ladder program to "interpret communication" to access the above device memories directly.

* **We call the communication which can access the device memories "interpreting communication" in this manual.**

Inserting this Function in the ladder program of the master CPU makes it possible for V6 to access any memory address by the "interpreting communication" using our original exclusive protocol. About the procedure of inserting our Function in the master program, refer to page 4-3 for more details.

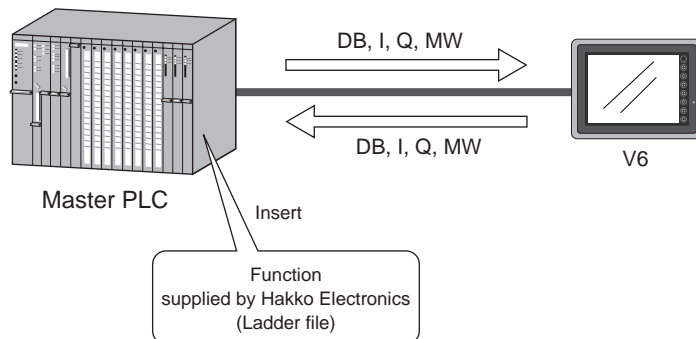

2

Specifications

PROFIBUS Communication Specifications

For more information about general specifications or others, refer to the manual related to PROFIBUS.

Item	Specifications							
Number of stations	Slave station : 125 (maximum)							
Setting range of station number	1~125 (specified by the editor)							
System of transmission line	Bus system (multi drop)							
Transmission line	Bus transmission line: shielded twist pair cable (The total extended distance depends on baud rate.)							
Transmission mode	Half-duplex, Serial transmission, adhering to EIA RS-485							
Communication setting	Data length : 8 Parity : Even Stop bit : 1							
Baud rate (bps)	9600	19200	93750	187500	500000	1.5M	12M	
Transmission distance (m)	1200	1200	1200	1000	400	200	100	
Encoding mode	NRZ (Non Return to Zero) mode							
Possessed inputs/outputs	Inputs/outputs: 1~48 words (selected from 32, 64 or 96 bytes by the editor)							



V6 series can communicate with PROFIBUS-DP only when the master CPU is S7, and it works as a slave station. It cannot correspond with S5 as PROFIBUS-DP communication.

MEMO

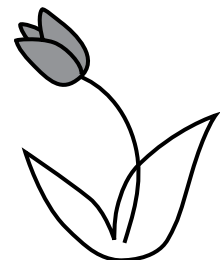

Please use this page freely.

3

Settings at the V6 Side & Wiring

Installation to the V6 and Settings

Communication interface unit

Our PROFIBUS communication I/F unit (CU-04) is required for PROFIBUS communication with V6.

Check the following model name of PROFIBUS I/F unit in accordance with the model of the V6.

Model of V6	Model Name of PROFIBUS I/F Unit
V612	CU-04
V610	
V608	
V606i	



Notes on using CU-04 as the unit compatible with CE marking

It is possible to use this unit as the model compatible with CE marking, provided you use this unit according to the following conditions.

Compatible models

V612xx0D-CE

V610xx0D-CE

V608C10-CE

V606i (hardware version "I" or later)

* **CU-04 can be compatible with CE marking under the condition that it should be installed in the above models.**

Notes on using other accessories

When using both CU-04 and CREC (card recorder) simultaneously, it cannot be compatible with CE marking.

Dimensions of PROFIBUS I/F unit

◎ CU-04 (Unit : mm)

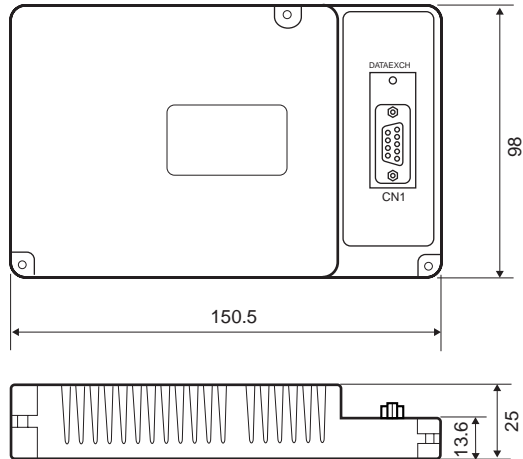

◎ Dimensions when the I/F unit is mounted to the V6 (Unit : mm)

● V612

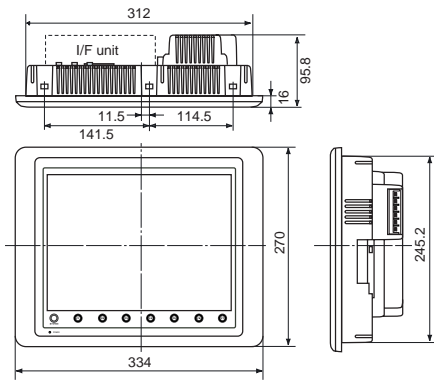

● V610

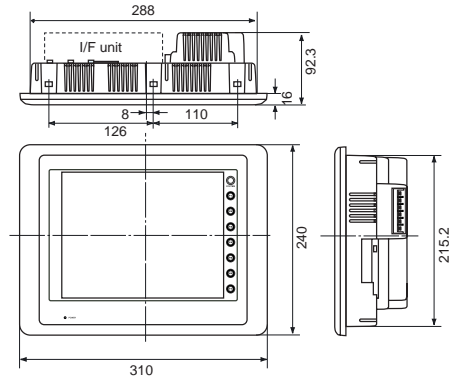

● V608

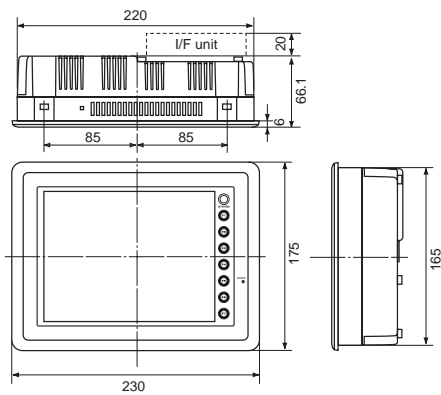

● V606i

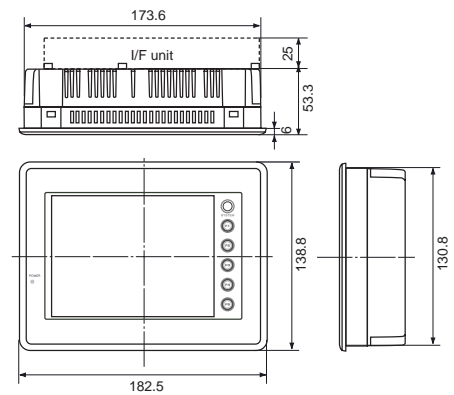

How to install a PROFIBUS I/F unit

- ⊙ Remove a dust protection seal being pasted behind a V6, and mounting the PROFIBUS I/F unit, then fix with the mounting screws (M3 X 8) at 3 places.
- ⊙ Wire the communication cable.
For more details, refer to page 3-6.

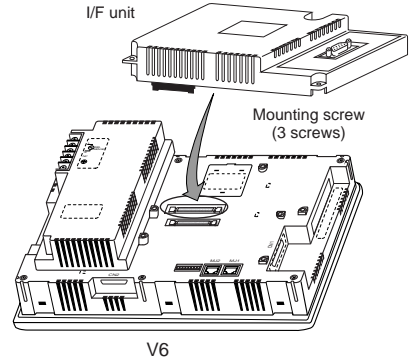

- ⊙ In the V608 or V606i case, insert a spacer at the mounting hole of the upper left of V608 or the lower left of V606i (the lower left of CU-04), then fix with the mounting screws (M3 X 15) attached onto PROFIBUS I/F unit.
(Torque: 0.3 ~ 0.5N·m (3 ~ 5kgf·cm))

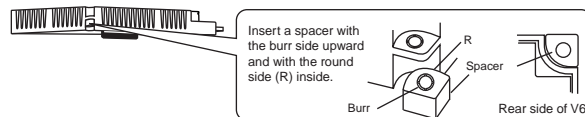

Setting at PROFIBUS I/F Unit Side

Outline of PROFIBUS I/F unit

The PROFIBUS I/F unit is as follows;

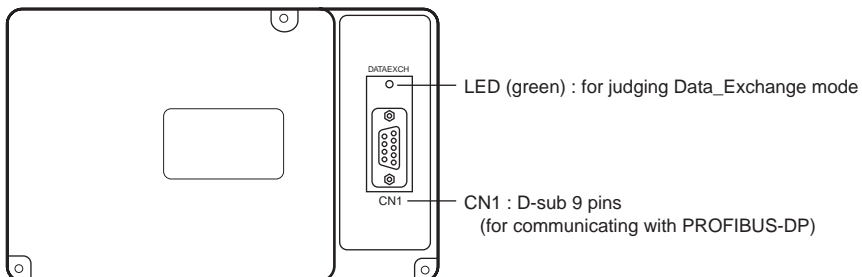

◎ LED

Lights up during the communication with PROFIBUS-DP.

◎ CN1

This is the connector for communication.
About the wiring, refer to the next page.

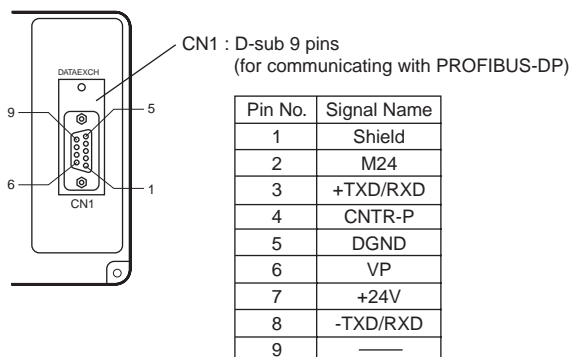

Wiring

When connecting V6 to PROFIBUS, use the exclusive cable for PROFIBUS-DP produced by SIEMENS.

Cable

The following is the model type of the cable we recommend. For more information about the detail specifications of the cable, or way of connection, refer to the related manual produced by SIEMENS.

Maker	Type
SIEMENS	6XV1830-00EH10

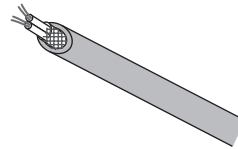

Recommended bus connector

We recommend using the connector that is called "Bus Connector" of RS-485 for the cable on PROFIBUS. Using the bus connector makes it possible to connect the cables for PROFIBUS easily.

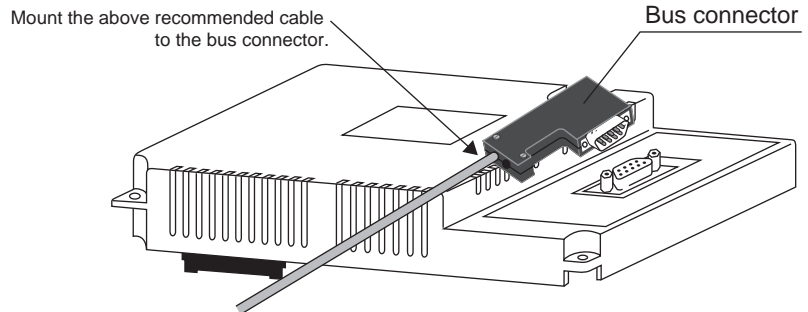

The following is the list of the model types for the bus connectors we recommend.

For more information about the detail specifications of the connectors, or way of connection, refer to the related manual produced by SIEMENS.

Maker	Type
SIEMENS	6ES7 972-0BA11-0XA0
	6ES7 972-0BB11-0XA0
	6ES7 972-0BA40-0XA0
	6ES7 972-0BB40-0XA0
	6ES7 972-0BA50-0XA0
	6ES7 972-0BB50-0XA0

Notes on using V606i

When using V606i, attaching a ferrite core onto communication cable near the connector of V606i is recommended. When using V606i in the environment influenced by noises, be sure to attach a ferrite core as above mentioned.

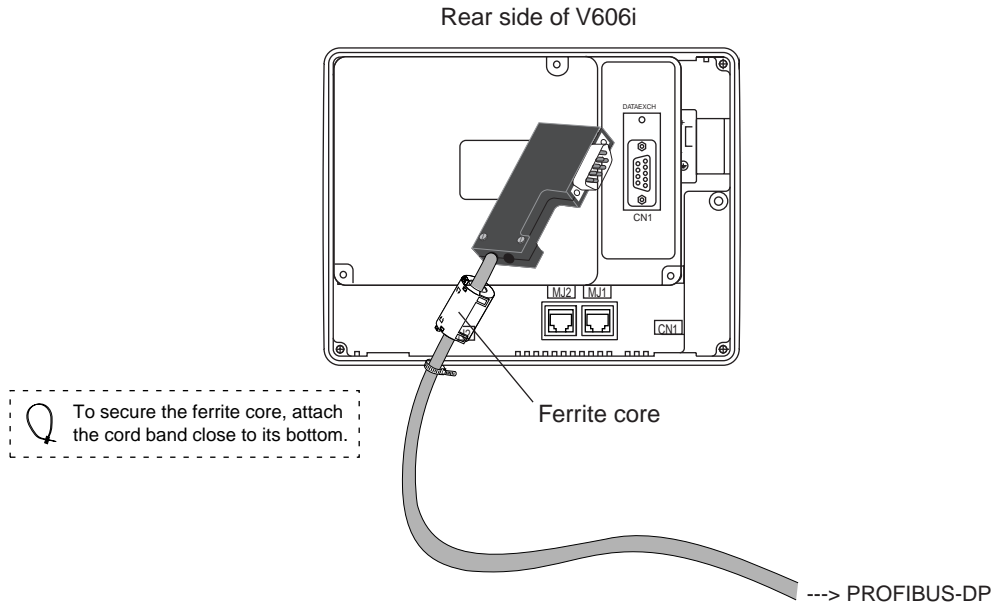

Notes on using CU-04 as the unit compatible with CE marking

In case of attaching this unit to V606i (hardware version "I" or later): When using this unit as the model compatible with CE marking, be sure to attach a ferrite core onto communication cable near the connector of V606i, and connect FG terminal of V606i to FG of this unit via FG wire attached to this unit, as shown below.

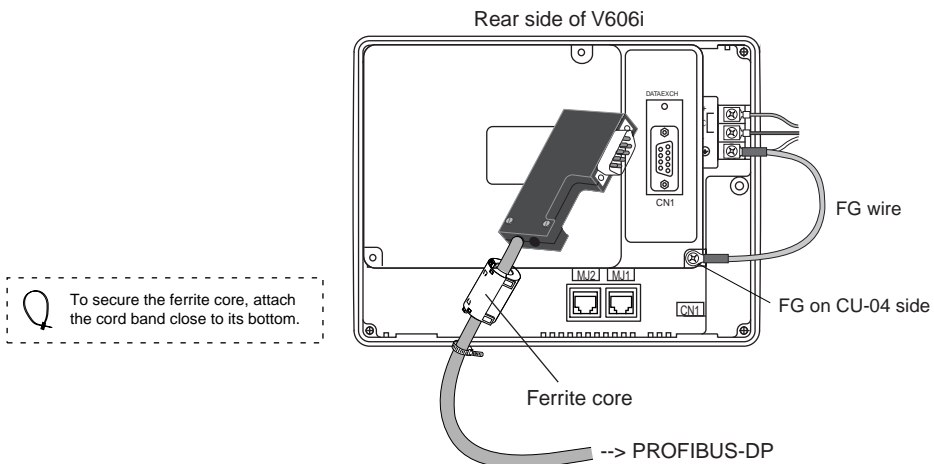

4

Connection to PLC

It is necessary to insert the original Function in the ladder program of the master CPU to make the [interpreting communication] available so that V6 can communicate with PLC (PROFIBUS-DP master).

Interpreting Communication

Outline

PROFIBUS-DP can only support the input/output communication with the cyclic data exchange.

In the input/output communication, the device memories in a CPU, such as DB, MW etc. cannot be accessed directly.

Therefore, we supply the original Function for SIEMENS ladder program to "interpreting communication" to access the above device memories directly.

*** We call the communication that can access the device memories "interpreting communication" in this manual.**

Inserting this Function in the ladder program of the master CPU makes it possible for V6 to access any memory address by the "interpreting communication" using our original exclusive protocol.

The [SIMATIC Manager] is used for inserting the Function supplied by Hakko Electronics in the ladder program.

Refer to "Setting in SIMATIC Manager" (page 4-3) for more details.

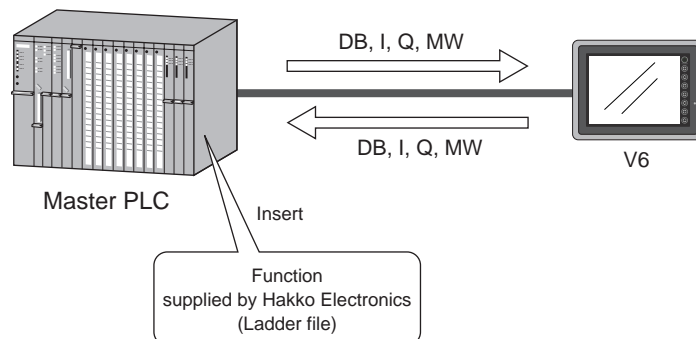

Available memories

V6 can access the following memory addresses by the interpreting communication.

	Memory	Bit Write	TYPE *1)	Remarks
DB	(data register)	○	0	
I	(input relay (bit))	○	1	
IW	(input relay (word))	×	1	
Q	(output relay (bit))	○	2	
QW	(output relay (word))	×	2	
M	(internal relay (bit))	○	3	
MW	(internal relay (word))	×	3	

***1) Use TYPE number to assign indirect memory for macro programs.**

***2) There may be a limit to the setting range of each memory address according to the PLC type.**

Setting in SIMATIC Manager

This section explains the settings necessary for V6 to communicate with PROFIBUS-DP by the interpreting communication, or the related matters in SIMATIC Manager.

For more information about the way to use SIMATIC Manager etc., refer to the related manual produced by SIEMENS.

The following items must be set so that V6 can communicate with PLC (PROFIBUS-DP master CPU) by the interpreting communication.

- 1) Insert the original Function in the ladder program on SIMATIC Manager.
- 2) Specify the communication parameters on V-SFTE.
(Note that the setting on V-SFTE is in agreement with that on SIMATIC Manager.)

This section explains the item 1).

About the item 2), refer to the chapter 5, "Screen Data Editing" (page 5-1).

Our software package

You can see the [PROFIBUS-DP] folder in the CD-ROM of the V6 series editing software, V-SFTE. The contents are as follows;

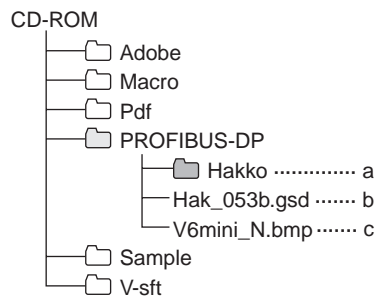

- a. Project file
includes the original Function.
- b. GSD file for MONITOUCH
Data file used for setting the parameters of V6 series on SIMATIC Manager
- c. Bitmap file
shows the view of V6 series with bitmap, and is used for setting V6 series in the ladder program on SIMATIC Manager.

Registration of V6 series

It is necessary to register each file supplied by Hakko Electronics before setting V6 series on SIMATIC Manager.

Registration of GSD file

1. Copy the GSD file for MONITOUCH, [Hak_053b.gsd] (b), in the CD-ROM.
2. Paste the above file to the folder [\\Siemens\\Step7\\S7data\\gsd] in the hard disk where SIMATIC Manager is installed.

Registration of bitmap file

1. Copy the bitmap file, [V6mini_N.bmp] (c), in the CD-ROM.
2. Paste the above file to the folder [\\Siemens\\Step7\\S7data\\nsbmp] in the hard disk where SIMATIC Manager is installed.

Confirmation of registration

1. Start SIMATIC Manager, then open a project.
2. Start [Hardware Configuration].

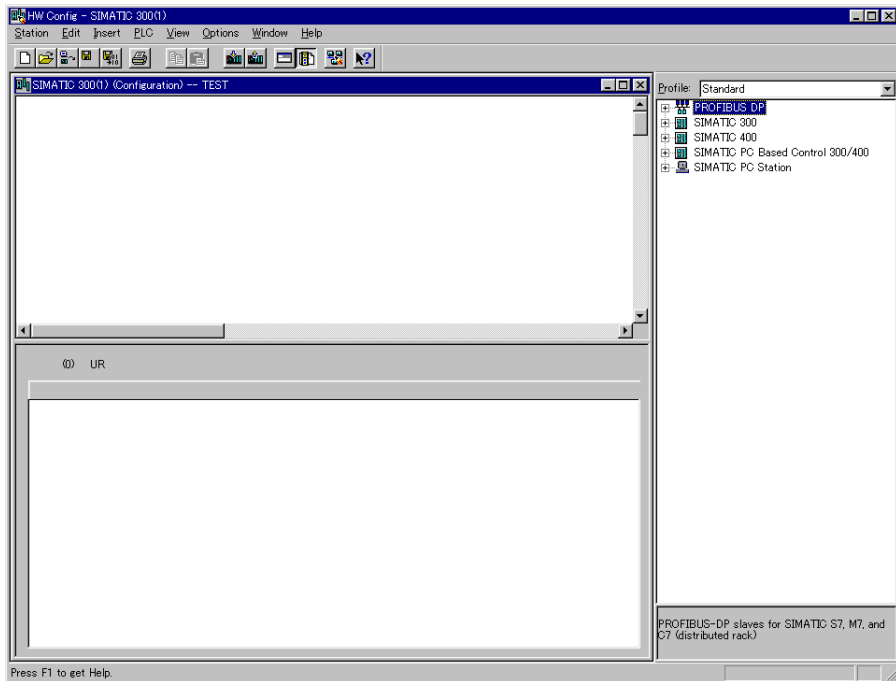

3. Click [Update Catalog] of [Option]. The contents for V6 series are renewed according to the registered file.

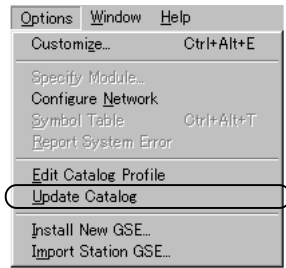

4. Check that there is the [V6series] folder in [MMI] of [Additional Field Devices] of [PROFIBUS-DP] in the [Catalog] tree.

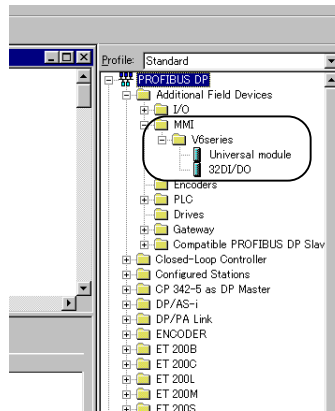

Setting of Hardware Configuration

Specify V6 series in the project for PROFIBUS-DP.

1. Open the existing project for PROFIBUS-DP.
2. Start [Hardware Configuration].
3. Drag the [V6series] folder in the [Catalog] tree, then release it on the [PROFFIBUS-DP] line.

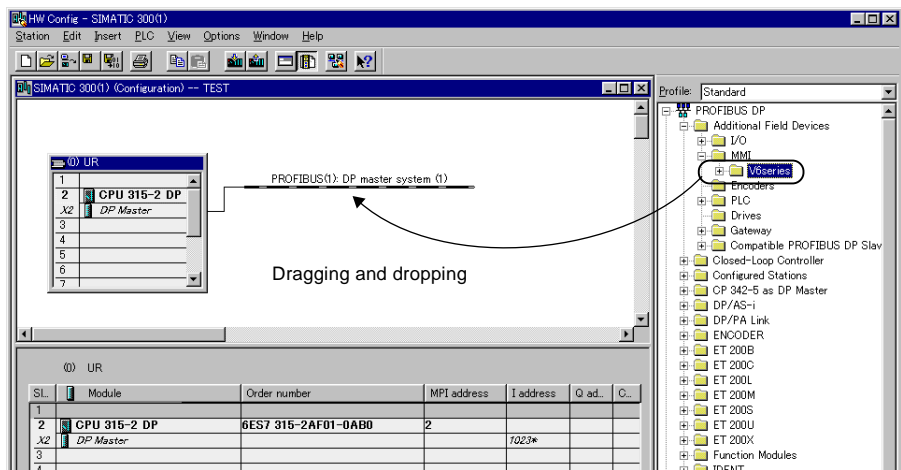

4. Set the station number of [V6series].

- 1) Double-click [V6series] on the [PROFIBUS-DP] line.
The following dialog is displayed.

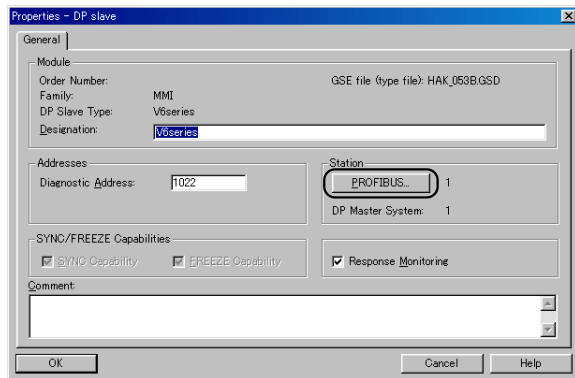
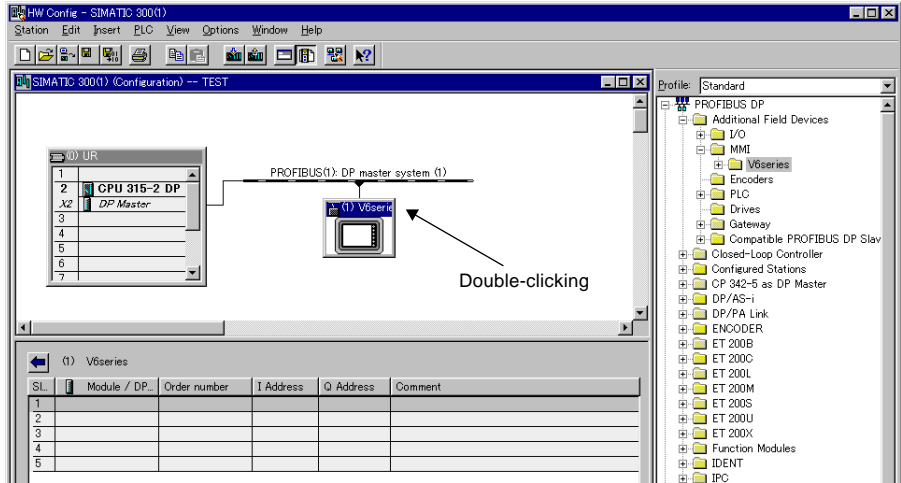

- 2) Click the [PROFIBUS] button.

The following dialog is displayed.

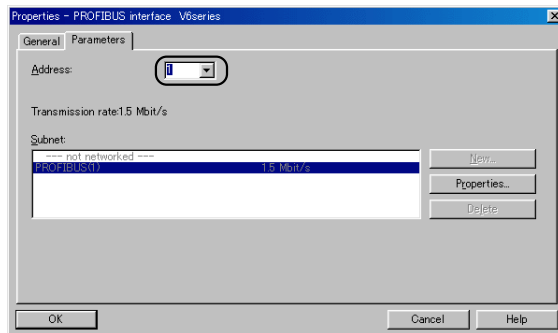

- 3) Set the station number of V6 series in [Address].

5. Insert [Universal module] of [V6series] of the [Catalog] tree in [Slot 1] of [V6series] by dragging it.

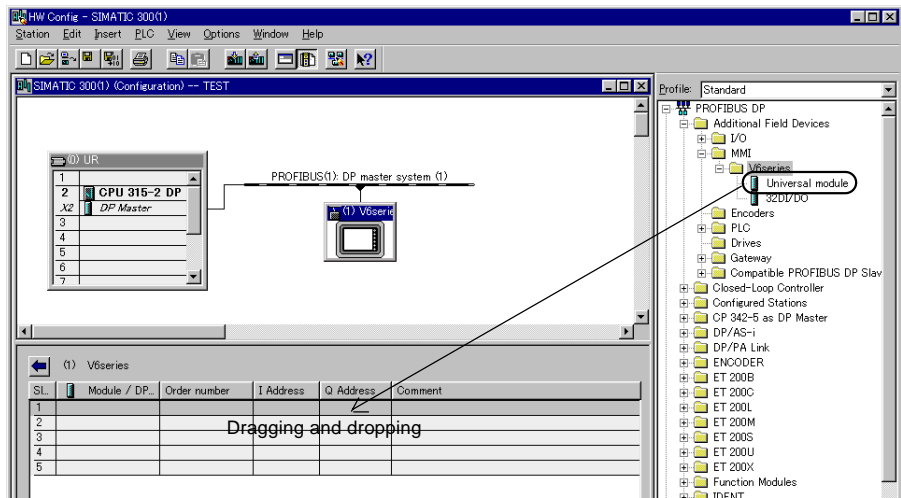

6. Insert [32DI/DO] of [V6series] of the [Catalog] tree in [Slot 2] or other slot area of [V6series] by dragging it.

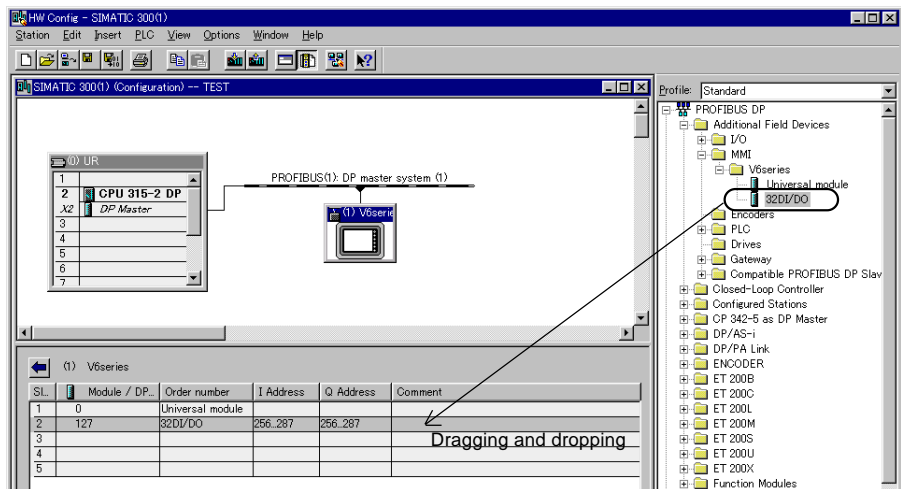

* One slot of [32DI/DO] can allow the exchange of 32-byte data at one communication. Also, two slots can allow the exchange of 64-byte data, and three slots can allow the exchange of 96-byte data, at one communication. A maximum of three slots can be inserted.

7. Specify the start addresses of both [Output] and [Input].
 - 1) Double-click [I Address] or [O Address] of each slot. The following dialog is displayed.

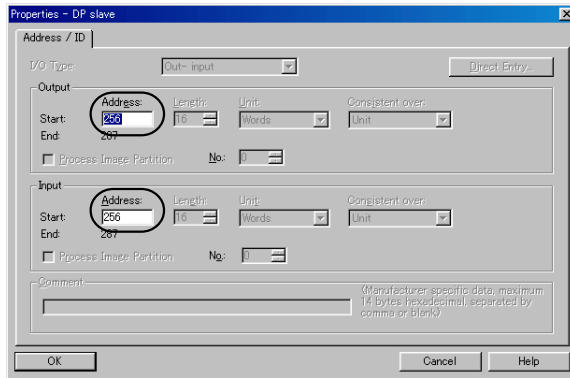

- 2) Specify each [Address] of [Start].

*** When using more than one slot of [32DI/DO], be sure to specify each address to allocate the used addresses consecutively.**

8. Up to this point all the settings of [Hardware Configuration] are completed.
 When using more than one V6 on PROFIBUS-DP, follow the procedure from 3. to 7. at the same number of times as the number of V6.

Setting of Function

Insert the Function supplied by Hakko Electronics necessary for the interpreting communication in the user's project.

1. Open the user's project.
2. Copy the [Hakko] folder in the CD-ROM, then paste it to some area of the hard disk you use.
3. Open the pasted [Hakko] project.
4. Copy the following [FC85] in the [Hakko] project.

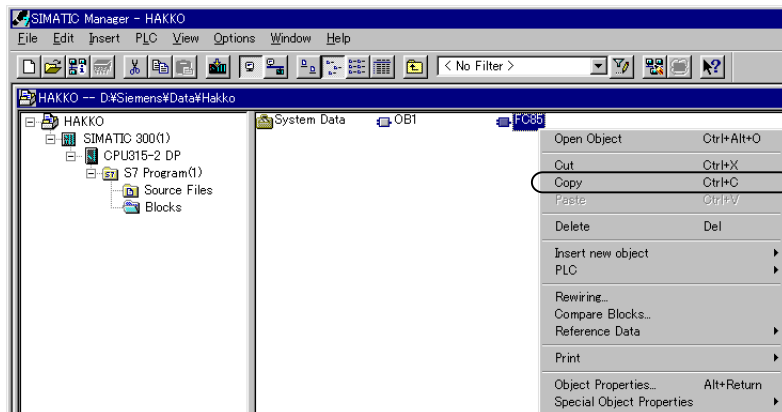

- Paste the above [FC85] to the same area of the user's project as the [Hakko] project.

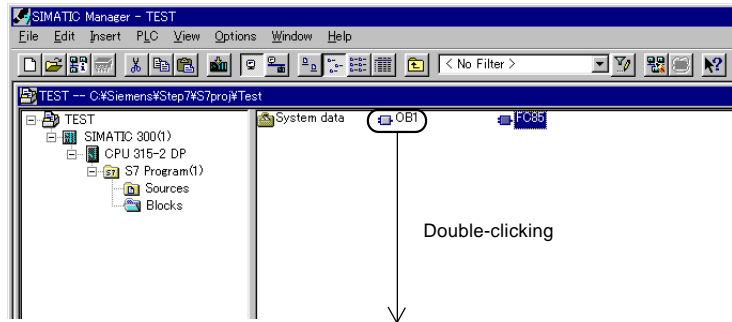

- Specify the command to call [FC85] in [OB1] of the user's project.
 - Double-click [OB1]. The following window is displayed.

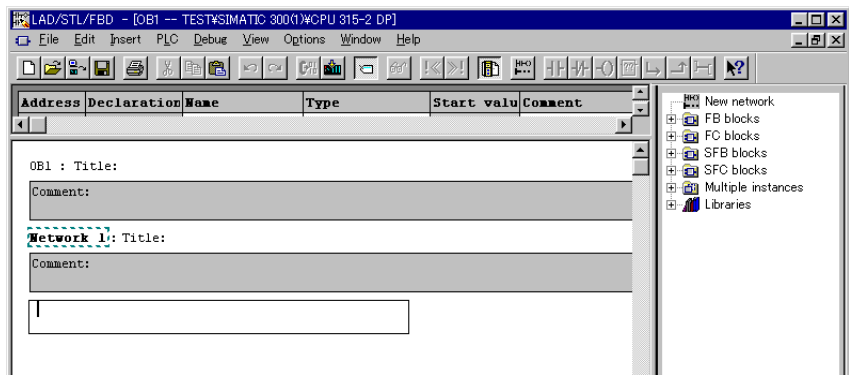

- Check that there is [FC85] in [FC blocks] of the [Catalog] tree.

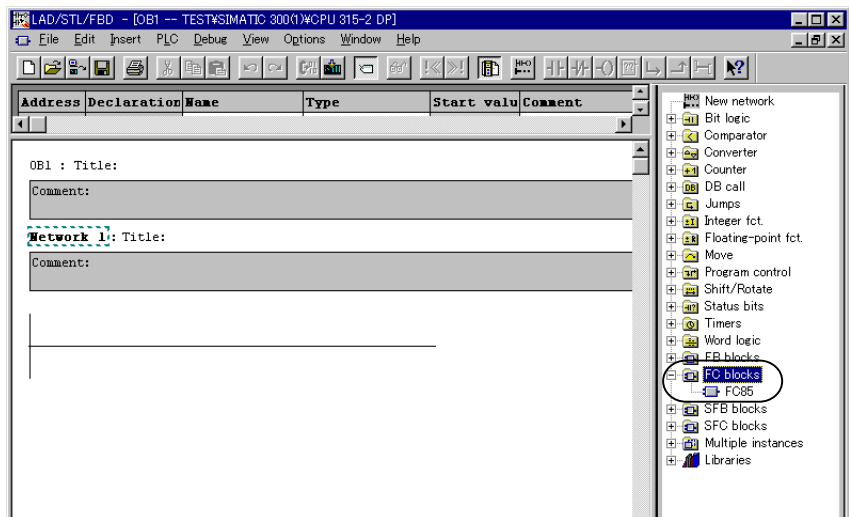

- Place the above [FC85] on the [OB1] project by dragging and dropping it. The window is shown below.

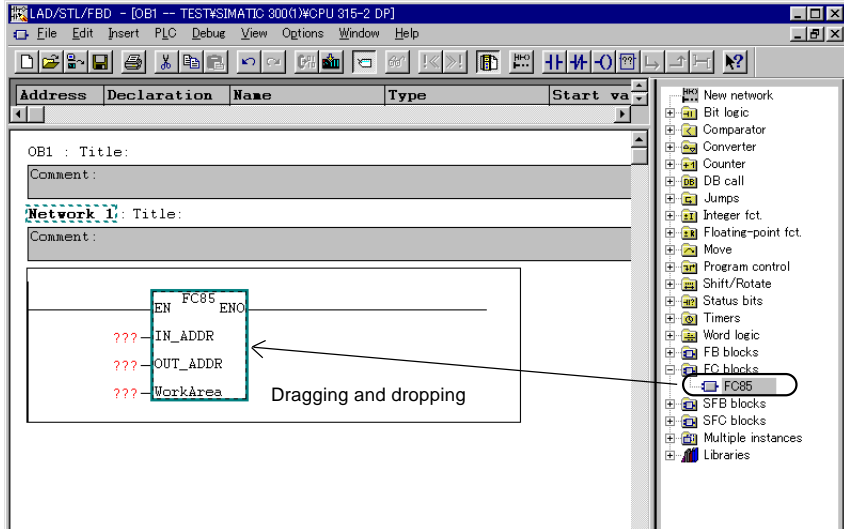

* **Be sure to insert [FC85] in the top of [OB1].**

- Specify the start addresses of both [IN] and [OUT], and 1 byte of work area (necessary per one V6), here.

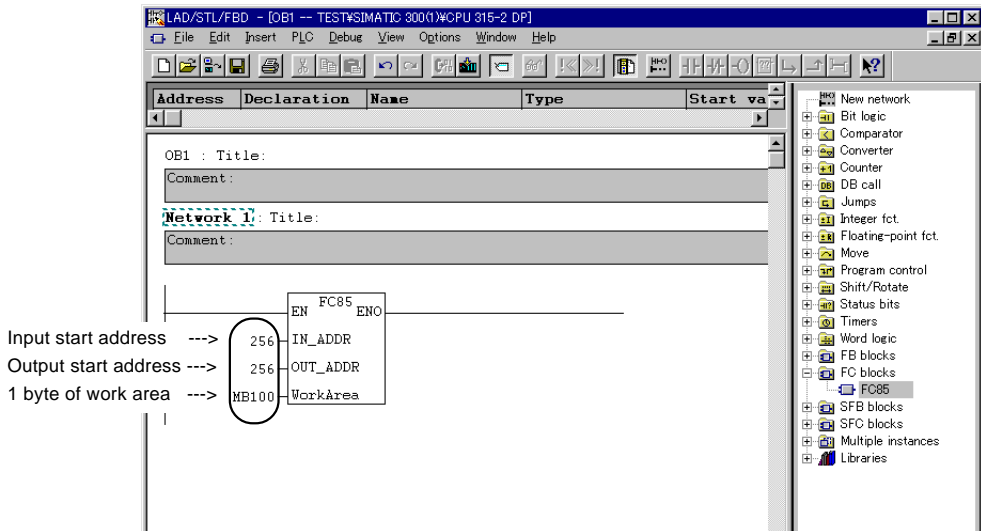

* **When using more than one V6 on PROFIBUS-DP, follow the procedure from 4. to 6. at the same number of times as the number of V6. Then, be sure not to specify the duplicate address for 1 byte of work area.**

* **When specifying [DB] device as a work area, be sure to specify not only the address but also the DB number.**

- Up to this point all the settings are completed.

5

Screen Data Editing

PROFIBUS can be supported in V-SFTE software version 1.2.16.0 or later (I/F driver [Pro_DP.tpb] version 1.200 or later). This chapter explains the setting items of V-SFTE to use PROFIBUS I/F unit (CU-04) for PROFIBUS-DP. For more information about the way to set or use V-SFTE, refer to [Reference Manual].

Select PLC Type

Click [Item], then click [PLC Type] of [System Setting]. Select [Siemens: S7 PROFIBUS-DP] on the [Select PLC Type] dialog.

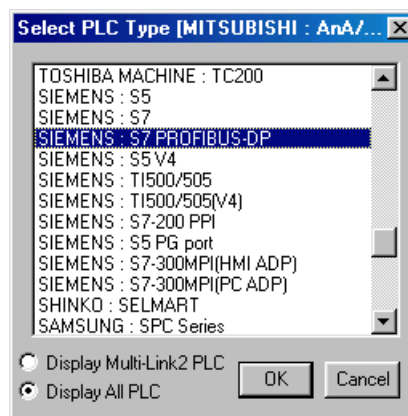

V6 series can communicate with PROFIBUS-DP only when the master CPU is S7, and it works as a slave station. S5 as PROFIBUS-DP communication is not supported.

Communication Parameter

It is not necessary to specify the communication parameter such as baud rate at the V6 side, because V6 can adjust the communication parameter to the master CPU side automatically.

No. of Words Setting for I/O

[Address]

Specify the station number (= Address) of V6 on PROFIBUS.
Be sure to specify the same address as specified as V6 on SIMATIC Manager.

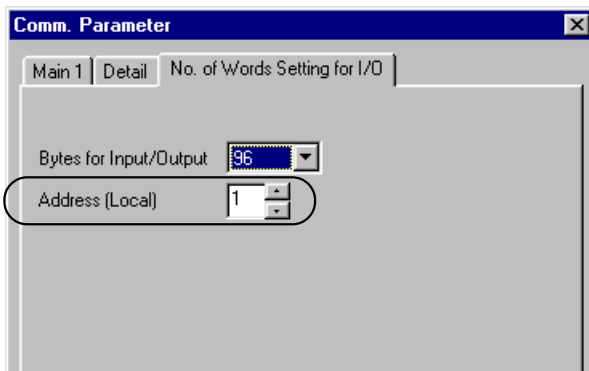

[Bytes for Input/Output] (32/64/96)

Select the data capacity to exchange between V6 and a master CPU on PROFIBUS-DP.

This setting must be the same as specified on SIMATIC Manager. Check the number of slots No. 2 (to 4) of [V6series] specified as [32DI/DO] on [Hardware Configuration].

If the number of [32DI/DO] slots is one, select [32] bytes. If it is two, select [64] bytes. If it is three, select [96] bytes. Select the proper capacity.

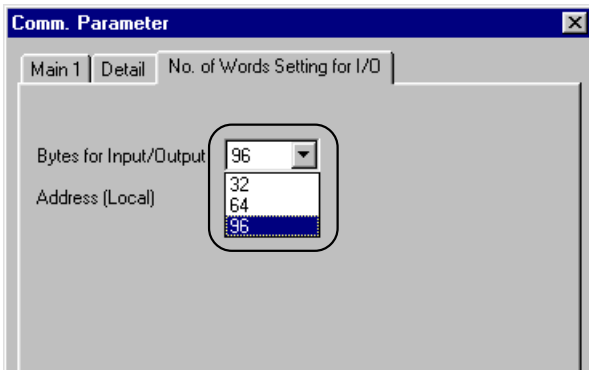

6

Error

This chapter explains the error messages to be displayed on V6 concerning with PROFIBUS-DP communication.

Communication Error (Time-Out)

If the communication error [Time-Out] is displayed on V6 as follows, the expected causes are shown on the next page.

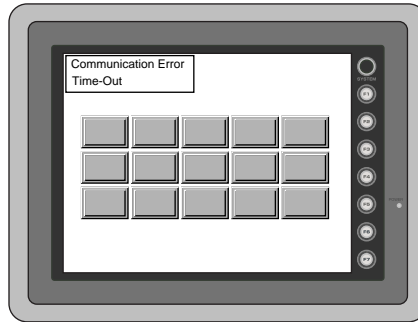

* When you go to [Comm. Parameter], bring up the [Detail] tab window and set [Stop] for [Comm. Error Handling], a screen like the one shown below is displayed.

However, if the communication between V6 and PROFIBUS-DP stops completely, a master CPU may not retry the communication automatically, in addition, the error may happen to other devices on PROFIBUS-DP.

Therefore, we recommend the setting [Comm. Error Handling: Continue] as the default setting.

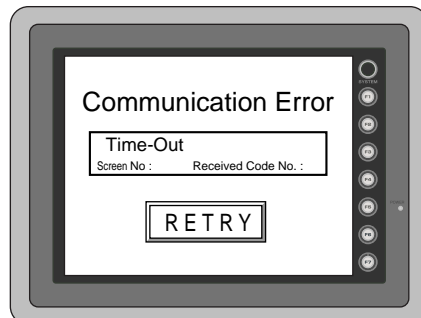

If [Time-Out] happens instantly;

Condition : When connecting V6 to PROFIBUS-DP with RUN mode, the screen [Communication Error Time-Out] is displayed a few seconds after the [Check] screen is displayed.

Cause : There is the possibility that the setting of [Address] on V6 side is not the same as specified on SIMATIC Manager. Check both settings, and specify it again.

**If [Time-Out] happens
after a screen is displayed for a moment;**

Condition : When connecting V6 to PROFIBUS-DP with RUN mode, the screen [Communication Error Time-Out] is displayed after a screen is displayed for a moment.

Cause : There is the possibility that the specified [DB] addresses on a screen of V6 do not exist in PLC (= memory over). Check the specified memories.

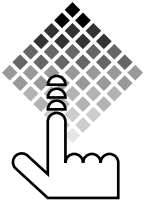

MONITOUCH

 **Hakko Electronics Co., Ltd.**

Sales	238, Kamikashiwano-machi, Matto-shi, Ishikawa, 924-0035 Japan
	TEL (076)274-5210 FAX(076)274-9696
Tokyo Office	TEL (03)3255-0166 FAX(03)3255-0298
Osaka Office	TEL (06)6385-8234 FAX(06)6385-7851
Nagoya Office	TEL (052)937-6147 FAX(052)937-6171
Head Office	209-2, Koh, Mameda-honmachi, Kanazawa-shi, Ishikawa, 920-0047 Japan